

**PCD7100-I (11956 & 11957 w/IRS) HARNESS ORDER SHEET**

**HARNESS IS NON CANCELLABLE AND NON RETURNABLE**

NAME: \_\_\_\_\_ DATE: \_\_\_\_\_  
 ADDRESS: \_\_\_\_\_ PHONE: \_\_\_\_\_  
 \_\_\_\_\_ Ship Method: \_\_\_\_\_  
 City: \_\_\_\_\_ State: \_\_\_\_\_  
 Zip/Post Code: \_\_\_\_\_  
 Visa/MC#: \_\_\_\_\_ Expiration: \_\_\_\_\_  
 Aircraft Make & Model: \_\_\_\_\_

Designation	Location	Length (feet)	Excess Length
LA	PCD7100-I to Aux Jacks (Radio Connection)		Additional cost if over 3 ft.
LP	PCD7100-I to Pilot Mic and Headphone Jacks		Additional cost if over 3 ft.
LC	PCD7100-I to Copilot Mic and Headphone Jacks		Additional cost if over 4 ft.
L1	PCD7100-I to Pass 1 Mic and headphone jacks		Additional cost if over 12 ft.
L2	PCD7100-I to Pass 2 Mic and headphone Jacks		Additional cost if over 10 ft.
M3	PCD7100-I to Passenger 3 Mic Jacks (6-place)		Additional cost if over 10 ft.
M4	PCD7100-I to Passenger 4 Mic Jacks (6-place)		Additional cost if over 10 ft.
H3	Pass 1 headphone to pass 3 headphone (6-place)		Additional cost if over 10 ft.
H4	Pass 2 headphone to pass 4 headphone (6-place)		Additional cost if over 10 ft.
E2*	PCD7100-I to Passenger Music Jack (#2) Check here to loop back to CD music. <input type="checkbox"/>		Additional cost if over 3 ft.
D	Dimmer connection, specify 14V or 28 V _____		Additional cost if over 4 ft.
IRS	PCD7100-I to Playback Switch (11957 only)		Additional cost
UNSW	Unswitched Inputs (2 available)		Additional cost if over 3 ft.
PG	Power and Ground		Additional cost if over 4 ft.

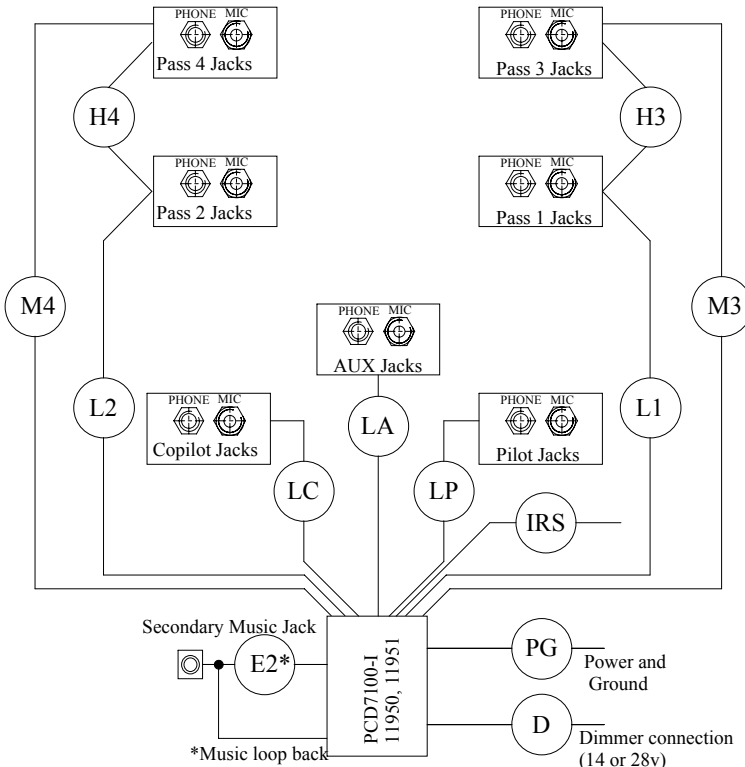

**Harness Part Number**  
 Please specify part number for intercom positions and if mic and headphone jacks are to be added.

- ◇ 15502 (2-place)
- ◇ 15503 (2-place with jacks)
- ◇ 15504 (4-place)
- ◇ 15505 (4-place with jacks)
- ◇ 15506 (6-place)
- ◇ 15507 (6-place with jacks)

**Notes:**  
*\*Music option:*  
 Specify if CD Music can be looped back for passenger in crew mode, **OR** connected to jack. Each harness is professionally manufactured using Mil-Spec, Tefzel shielded cable, and is clearly marked for easy identification using heat shrink labeling. Turn-around time is 2-business days from receipt of completed worksheet, or shipping is free.

**Special Instructions:**  
 \_\_\_\_\_  
 \_\_\_\_\_  
 \_\_\_\_\_